

Supreme Quality
Itco™

ACCURACY IN MICRONS

PITCH CONTROL TAPPING MACHINE

CAPACITY IN STEEL

8mm

CAPACITY IN CAST IRON

10mm

AUTOMATIC TAPPING MACHINE FOR MASS PRODUCTION

- ◆ ECONOMICAL HIGH PRECISION TAPPING
- ◆ CONFIRMS THREAD GO, NO-GO GAUGE
- ◆ CHANGE GEARS AS PER DIFFERENT THREAD SIZE
- ◆ DUAL CLUTCH SYSTEM PREVENTS TAP BREAKAGE
- ◆ PRECISE ADJUSTMENT OF TAPPING DEPTH
- ◆ LEAST SETUP TIME
- ◆ SPINDLE, SHAFTS & GEARS MADE OF ALLOY STEEL
"HARDENED & GROUND"
- ◆ MORE CONSISTENT THAN PNEUMATIC/ HYDRAULIC DRIVES
- ◆ REPEATABILITY OF STROKE WITHIN 1/5 PITCH OF THREAD

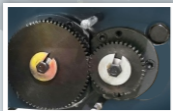
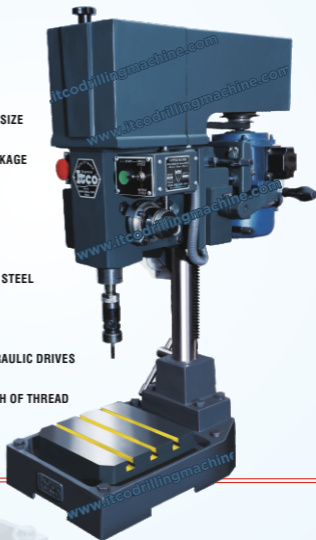

TECHNICAL SPECIFICATIONS

(All dimension are in mm)

Tapping capacity in Steel	: M3 to M8
Tapping capacity in CI	: M3 to M10
Max. spindle travel (mm)	: 45
Max. No. of strokes/(min)	: 50
Main Motor specification	: 1 HP, 1440 rpm, 3 phase
Spindle speed (rpm)	: 1350, 750, 400
Net Weight (Kg)	: 135



Also available: Fabricated stand with coolant pump & Tank

Standard Tapping (mm)	0.25, 0.3, 0.35, 0.4, 0.5, 0.6, 0.65, 0.7, 0.75, 0.8, 0.9, 1.0, 1.25, 1.5, 1.7
-----------------------	--

Pitches	100, 96, 90, 80, 72, 64, 56, 48, 44, 40, 36, 32, 28, 27, 24, 20, 18, 16
---------	---

A	: 315
B	: 850
C	: 480
D	: 240
E	: 270
F	: 635
G	: 430
H	: 440
I	: 235
J	: 60
K	: JT 2
L	: 184

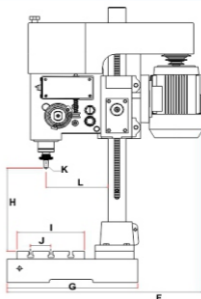
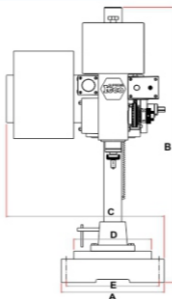

STANDARD ACCESSORIES

- Spare pulley for motor

EXTRA EQUIPMENT:

- Motor • V-belt • Tap Holder • Pitch gears for different pitches

Dealer



INDIAN ENGG.CORP.

E-mail: itcodrill@gmail.com www.itcodrill.com

Note: Modifications are made from time to time. Design & Specifications are subject to change without notice.